



**Ankica Milinković**, ankica.milinkovic@vekom.com, VEKOM Geo d.o.o. Belgrade

**Sanja Tucikešić**, sanja.tucikesic@aggf.unibl.org, Faculty of Architecture, Civil Engineering and Geodesy, University of Banja Luka

**Kornelija Ristić**, kornelija.ristic@aggf.unibl.org, Faculty of Architecture, Civil Engineering and Geodesy, University of Banja Luka

## VERIFICATION, CALIBRATION AND CONFORMITY ASSESSMENT OF ROTATING LASERS APPLIED IN BUILDING AND SURVEYING MEASUREMENT TASKS

### *Abstract:*

This paper specifies field procedures described by international norm ISO 17123-6, to be adopted when determining and evaluating the quality of rotating lasers and their ancillary equipment when used in building and surveying measurements for levelling tasks. It will be shown analysis and statistical tests in order to check the conformity of the equipment with the selected specifications. Also, this paper will promote the leveling systems delivered for complete quality verification of rotating lasers, as an automated reference laboratory system.

*Keywords:* quality, rotating laser, calibration, verification, statistical test, conformity, measuring

## ВЕРИФИКАЦИЈА, ЕТАЛОНИРАЊЕ И ОЦЕНА УСАГЛАШЕНОСТИ РОТАЦИОНИХ ЛАСЕРА КОРИШЋЕНИХ У ПОСЛОВИМА ИЗГРАДЊЕ И ПРЕМЕРА

### *Сажетак:*

Овај рад описује теренске поступке описане међународним нормом ИСО 17123-6, које треба усвојити приликом одређивања и оцене квалитета ротационих ласера и њихове помоћне опреме када се користе у изградњи и геодетским мерењима за послове нивелисања. Показаће се анализа и статистички тестови како би се проверила усаглашеност опреме са одабраним спецификацијама. Такође, овај рад ће промовисати мерни нивелациони систем који се успоставља за потпуну верификацију квалитета ротирајућих ласера, у виду примене аутоматизованог лабораторијског референтног система.

*Кључне ријечи:* квалитет, ротациони ласер, калибрација, верификација, статистички тестови, усаглашеност, мерење

## 1. INTRODUCTION

According to the International document *ISO 10012:2003 Measurement management systems — Requirements for measurement processes and measuring equipment*, only effective and efficient measuring management system is able to secure a quality of equipment, competent to reduce the appearing risk of incorrect measuring results. There are specifies generic requirements and guidance for the management of measurement and metrological processes, used to support and demonstrate compliance of equipment with metrological requirements. It specifies quality management requirements of a measurement management system that can be used by an organization performing measurements as part of the overall management system, and to ensure metrological requirements are met. Methods applied in measuring management process cover a wide range of activities, from the verification to the statistical techniques. All that activities describe one measuring management system as a set of interconnected or interacting elements required to achieve metrological validation and continuous management of measurement processes. For quality assurance, not only quality control is sufficient, but also a systematic approach that involves defining and providing other important factors: metrology, standardization, reliability, quality control, i.e.: personnel, methods and techniques, technical equipment, information, etc. In the system of integral quality management, metrology plays a prominent role in providing measurements of the physical quantities that characterize quality. From the metrological point of view, the focus is on providing measurement methods, measuring instruments (standards), measuring conditions and data processing methods of measuring.

Operators have obligations to use measuring equipment in way that secure accurate measurements, as well as they are responsible for both technical conformity of equipment and assuring the quality of delivered results. They ought to keep equipment in good technical shape, according to the methods specified in the manufacturer's handbooks. Even though operators do all checks on the field, equipment should be officially tested and calibrated in regarding to recognized procedures described in national or international relevant documents, norms, by-laws. Further, reporting of calibration and testing results could show statements of conformity, with respect to the specifications required whether from investors, custodies, or any stakeholders.

This paper specifies field procedures described by international norm ISO 17123-6:2012 Optics and optical instruments — Field procedures for testing geodetic and surveying instruments — Part 6: Rotating lasers, to be adopted when determining and evaluating the quality of rotating lasers and their ancillary equipment when used in building and surveying measurements for levelling tasks. The first one procedure provides an estimate as to whether the precision of a given item of rotating-laser equipment is within the specified permitted deviation, according to ISO 4463-1. The second one procedure provides the best achievable measure of precision of a particular rotating laser, the deflective deviation from the true horizontal, and both components of the deviation of the rotating axis from the true vertical. In the end, it will be shown analysis and statistical test in order to check the conformity of the equipment with the selected specifications. At the same time, paper will promote extra the leveling systems delivered for complete quality verification of rotating lasers, as an automated reference laboratory system.

## 2. QUALITY ASSURANCE OF MEASURING EQUIPMENT

There are three general principles that apply in considering the quality assurance aspects of instruments and equipment. The first is that the equipment should be capable of doing the job required of it. The second principle is that all equipment should be kept in optimal condition for use as needed. This implies both preventive maintenance and control over the use of the equipment by personnel. The third principle is that equipment should be frequently monitored and evaluated, what implies calibration [1]. Calibration means operation that, under specified conditions, in a first step, establishes a relation between the quantity values with measurement uncertainties provided by measurement standards and corresponding indications with associated measurement uncertainties and, in a second step, uses this information to establish a relation for obtaining a measurement result from an indication [2]. Understanding and quantifying the uncertainty of measurements as well as measurement errors, are critical to maintaining quality of equipment.

### 2.1. Uncertainty of measurements and measurement errors

The most important concept to understand is that all measurements have uncertainty. In fact, it can be never known the exact true value of anything, all measurements are actually estimated, and have some uncertainty. The difference between a measurement result and the true value is the

measurement error. Since the true value is unknown, also can't know the error: these are unknowable quantities. All what can be quantified are the results of measurements and these always have some uncertainty, even if this uncertainty is very small. On the Figure 1 is shown interpretation of uncertainty and measurement error [3].

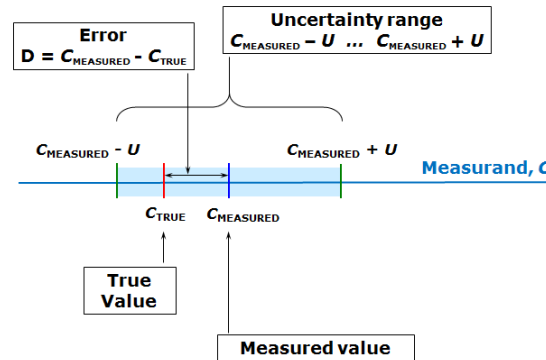

Figure 1. Interrelations between the concepts true value, measured value, error and uncertainty. (Figure source given in Literature [3])

There are two widely used methods to quantify the uncertainty of a measurement. Calibration laboratories and scientific institutions normally carry out Uncertainty Evaluation according to the Guide to the Expression of Uncertainty in Measurement (GUM). The GUM method involves first considering all of the influences which might affect the measurement result. A mathematical model must then be determined giving the measurement result as a function of these influence quantities. By considering the uncertainty in each input quantity and applying the 'Law of Propagation of Uncertainty' an estimate for the combined uncertainty of the measurement can be calculated. The GUM approach is sometimes described as bottom-up, since it starts with a consideration of each individual influence. Each influence is normally listed in a table called an uncertainty budget which is used to calculate the combined uncertainty. Industrial measurement processes are typically evaluated using a Measurement Systems Analysis (MSA) approach, as recommended within the Six-Sigma methodology, and usually following the guidelines of the Automotive Industry Action Group (AIAG) MSA Reference Manual. MSA involves performing Gage Studies in which repeated measurements are compared with a reference under different conditions to determine the bias, repeatability and sometimes reproducibility. In the Chapter 4 of this paper will be presented Type A GUM method of uncertainty measurement estimation during the procedure of rotating laser calibration.

Calibration and the associated concept of traceability are the fundamental aspects of uncertainty, where calibration is a comparison with a reference, and the uncertainty of this comparison must always be included. A traceable measurement is one which has an unbroken chain of calibrations going all the way back to the primary standard. A measurement is traceable if there is an unbroken chain of calibrations back to the primary standard (In the Figure 2 is illustrated one traceability chain in general).

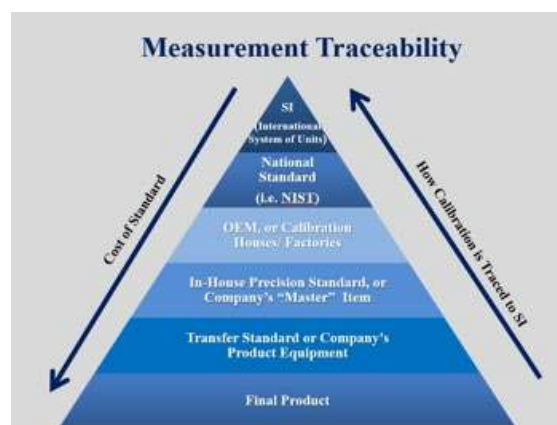

Figure 2. Traceability chain (Figure source given in Literature [4])

All measurements must be traceable back to the same standard to ensure that parts manufactured in different countries will fit together. In this process, national and international metrology institutions as well as competent calibration laboratories play the main roll.

The uncertainty of measurements arises from different sources. Some of these will lead to a consistent error, or bias, in the result. For example, the unknown error present when an instrument was calibrated will lead to a consistent error whenever it is used. This type of effect is known as a systematic uncertainty leading to a systematic error. Other sources will lead to errors which change randomly each time a measurement is made. It is conventional to divide random uncertainty into repeatability, the random uncertainty of results under the same conditions, and reproducibility, the random uncertainty under changed conditions. The conditions can never be exactly the same or completely different so the distinction is somewhat vague. The types of conditions which might be changed are making the measurement at a different time, with a different operator, a different instrument, using a different calibration and in a different environment. Once determined the uncertainty (or 'accuracy') of a measurement can apply this to decide whether a part conforms to a specified tolerance.

Each measurement is associated with the determination of numerous values of physical quantities by which the regularities of the phenomena under study are realized. Measuring a quantity means to determine its numerical relationship with another of the same size, with the adoption of a unit of measure. When measuring, data on different physical quantities must be provided: discrete and continuous, constant and variable, dependent and independent. Therefore, measurement is considered to be a process of physically equating a given value with its physical value taken for a unit of measure. The result of the measurement is presents as quantitative information about the basic properties of a measuring object, obtained as a result of a physical process with a certain degree of accuracy. Each measurement process is accompanied by inevitable measurement errors. Depending on the degree of perfection of knowledge, the means of measurement and the conditions under which the measurement is conducted, the size of these errors is also different. The result of each measurement occurs as a function of two independent quantities, one reflecting the true value of the measured size, and the other, representing the error of its measurement. Therefore, the measurement error of some size should be considered as the difference between the measurement results and the true value of the measured size. The true value of the measured size is unknown to the technique of measurement. The reason for this is the imperfection of the criterion. With the reduction of the measurement error, we are increasingly approaching the true value of the measured size.

The measurement error of some quantity is directly related to the accuracy and precision of the measurement. Measurement accuracy means, in the general case, the quality or validity of the measurement, ie. the degree of closeness between the measurement results and the true value of the measured size. The accuracy of a measurement of some quantity is all the greater the smaller the error of its measurement. Therefore, the measurement error of the given size is quantitatively expressed. Measurement accuracy is defined by the repeatability of measurement results, ie the degree of scattering or mutual matching of individual measurement results. These results are obtained by successive, multiple repetitions of a measurement operation over a measuring size, whose value is time independent (constant). This means that the precision of a measurement is greater if there is less dispersion of the individual values of the measurement results in the set of results of repeated measurements, or if the mutual agreement of these values is greater, what is presented on the Figure 3.

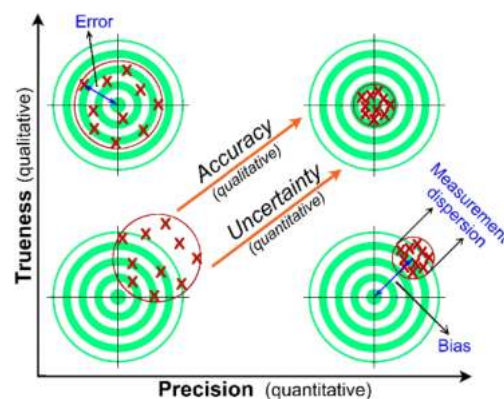

Figure 3. Accuracy and Precision (Figure source given in Literature [10])

### 3. QUALITY ASSURANCE OF MEASURING RESULTS OBTAINED USING AN ROTATING LASER

Construction lasers are used as an accurate level reference during any layout process. In surveying and construction, the laser level is a control tool that includes a laser beam projector which is affixed to a tripod, leveled, and rapidly spun to indicate a horizontal plane. The laser beam projector has a rotating head with a mirror that sweeps the laser beam around a vertical axis. Some mirrors are self-leveling, while others can be manually adjusted.



Figure 4. Rotating and linear lasers levels (Figure source given in Literature [5])

Rotating laser levels are used for construction projects indoors to shoot a 360-degree horizontal or vertical beam around a room, or outdoors to be used with a laser detector and grade rod for excavation for both digging down or building up. There are a variety of rotating laser levels to choose from, (Figure 4). It can be manually-leveling using a mounted bubble level, electronically self-leveling which uses a pendulum leveling system, or automatically self-leveling which uses electronics and gears to find level. Rotating laser levels project a beam of light 360-degrees, allowing the user to establish a horizontal or vertical plane. In fact, this beam of light is really a single dot of light that can rotate between 100 and 1,100 rmp, giving the appearance of a 360-degree chalk line. The beam of light is created by a diode, which in this case is simply a semiconductor which produces light when current passes through it. Color is technically determined by the wavelength of the laser, the laser diode actually, which is measured in nanometers (nm), one billionth of a meter, because of its very small length. The spectrum of color visible to the human eye is between 380 nm (purple) and 750 nm (red). Typically, the color of the laser is red (635 nm) or green (532 nm) which is near the center of the visible spectrum, making it the most visible to the human eye. The intensity of the laser is determined by the level of laser light power which is measured in milliwatts (mw), 0.001 or one-thousandth of a watt [5].

Before commencing surveying, it is important that the operator investigates that the precision in use of the measuring equipment is appropriate to the intended measuring task. The rotating laser and its ancillary equipment shall be in known and acceptable states of permanent adjustment according to the methods specified in the manufacturer's handbook, and used with tripods and levelling staffs as recommended by the manufacturer. The results of measuring are influenced by meteorological conditions, especially by the temperature gradient. An overcast sky and low wind speed guarantee the most favourable weather conditions. The particular conditions to be taken into account may vary depending on the location where the tasks are to be undertaken [7]. Rotating lasers have to be verified and calibrated before application.

The 6<sup>th</sup> part of the ISO 17123 norm describes two different field procedures for calibration of rotating leveling lasers. The first one, called the simplified test procedure provides an estimate as to whether the precision of a given item of rotating-laser equipment is within the specified permitted deviation, according to ISO 4463-1. This test procedure is normally intended for checking the precision of a rotating laser to be used for area levelling applications, for tasks where measurements with unequal site lengths are common practice, e.g. building construction sites. Since, the simplified test procedure is based on a limited number of measurements, therefore, a significant standard deviation and the standard uncertainty (Type A), respectively, cannot be obtained, this method won't be analyzed here.

The second one, called the full test procedure shall be adopted to determine the best achievable measure of precision of a particular rotating laser and its ancillary equipment under field conditions, by a single survey team. Further, this test procedure serves to determine the deflective deviation,  $a$ , and both components of the deviation of the rotating axis from the true vertical of the rotating laser



equidistant between the levelling points, A and B ( $40/2 = 20$  m). For the full test procedure,  $i = 4$  series of measurements should be performed. In each series, three instrument setups S1, S2 and S3 are chosen, according to the configuration given in Figure 8. At any setup  $n = 4$  sets of readings are taken. Each set consists of two readings  $x_{Aj}$ , and  $x_{Bj}$ , namely to rod A and to rod B. After each set, the orientation of the instrument has to be changed clockwise about  $90^\circ$ . Hence one series consists of  $j = 3 \times 4 = 12$  readings for each rod. In order to ensure that the instrument deviation  $b$  is aligned properly during the measurements, the instrument has to be oriented at the three positions S1, S2 and S3 in the same direction and the sense of rotation has to be maintained.

With each new setup of the chosen reference direction (reference marks on the tripod head), the instrument shall be relevelled carefully. If the instrument is provided with a compensator, care shall be taken that it functions properly. It is recommended to assign the four orientations of the instrument on the ground plate, according to measurement organization shown in Table 2. The numbering of the 12 measurements can be represented for each measuring set. All readings shall be taken in a precise mode according to the recommendations of the manufacturer.

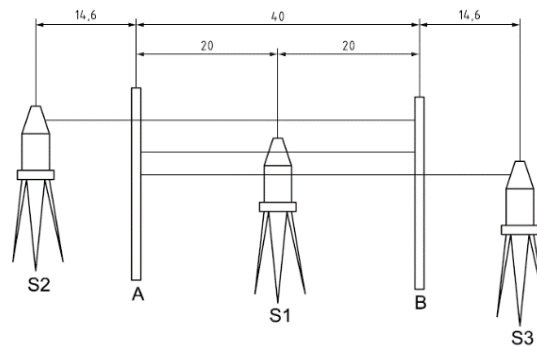

Figure 8. Configuration of the test line for the full test procedure

Apart of technical description of ISO 17123-6 document, there is one laboratory reference system for interpretation of this calibration procedures, so called Leica CalMaster systems. According to Leica Geosystems manufacturer of geodetical equipment, as well as rotating laser levels.

In order to create a horizontal sighting in the described measuring configuration, the readings at the levelling staffs for selected sighting distances can be corrected in respect of the deviations  $a$  and  $b$  (see Table 1).

Table 1. Corrections of the readings

Direction	Distance		
	14,6	20	54,6
1	$0,365(a + b_1)$	$0,500(a + b_1)$	$1,365(a + b_1)$
2	$0,365(a + b_2)$	$0,500(a + b_2)$	$1,365(a + b_2)$
3	$0,365(a - b_1)$	$0,500(a - b_1)$	$1,365(a - b_1)$
4	$0,365(a - b_2)$	$0,500(a - b_2)$	$1,365(a - b_2)$

From the observation formulae for the  $i_{th}$  series, the residuals,  $r_1$  to  $r_{12}$ , are obtained (see Table 2).

Table 2. The residuals  $r_1$  to  $r_{12}$

P=2	P=0,5	P=0,5
$r_1 = h - b_1 - (x_{B,1} - x_{A,1})$	$r_5 = h + a - b_1 - (x_{B,5} - x_{A,5})$	$r_9 = h - a - b_1 - (x_{B,9} - x_{A,9})$
$r_2 = h + b_2 - (x_{B,2} - x_{A,2})$	$r_6 = h + a + b_2 - (x_{B,6} - x_{A,6})$	$r_{10} = h - a + b_2 - (x_{B,10} - x_{A,10})$
$r_3 = h + b_1 - (x_{B,3} - x_{A,3})$	$r_7 = h + a + b_1 - (x_{B,7} - x_{A,7})$	$r_{11} = h - a + b_1 - (x_{B,11} - x_{A,11})$
$r_4 = h - b_2 - (x_{B,4} - x_{A,4})$	$r_8 = h + a - b_2 - (x_{B,8} - x_{A,8})$	$r_{12} = h - a - b_2 - (x_{B,12} - x_{A,12})$

where

$p$  is the weighting factor for one reading at the levelling staff ( $p = 1$  for a sighting distance of 40 m);  
 $h$  is the height difference between the levelling staffs B and A.

**Table 3.** Organization of measurement

Instrument setups for each series, $i=1, \dots, 4$	A__S1__B	A_S2_____B	A_____S3_B
Set $n$ orientation, $n=1, \dots, 4$	Readings $x_{Aj}, x_{Bj}$ , $j=1, \dots, 4$	Readings $x_{Aj}, x_{Bj}$ , $j=5, \dots, 8$	Readings $x_{Aj}, x_{Bj}$ , $j=9, \dots, 12$
Set 1 →	$x_{A1} x_{B1}$	$x_{A5} x_{B5}$	$x_{A9} x_{B9}$
Set 2 ↓	$x_{A2} x_{B2}$	$x_{A6} x_{B6}$	$x_{A10} x_{B10}$
Set 3 ←	$x_{A3} x_{B3}$	$x_{A7} x_{B7}$	$x_{A11} x_{B11}$
Set 4 ↑	$x_{A4} x_{B4}$	$x_{A8} x_{B8}$	$x_{A12} x_{B12}$

For the interpretation of above, producer of geodetic instruments, Leica Geosystems has developed laboratory reference systems for rotating laser levels calibration, Leica CalMaster. CalMaster is an intuitive and compact system to check and adjust rotating lasers and issue calibration reports, checking and calibration system in the industry to issue the ISO 17123-6 certification for repeated accuracy and reliability of rotating lasers. The system consists of a specially modified and programmed Leica Sprinter level, CalMaster software, interface to communicate with rotating lasers and accessories. Figure 9.

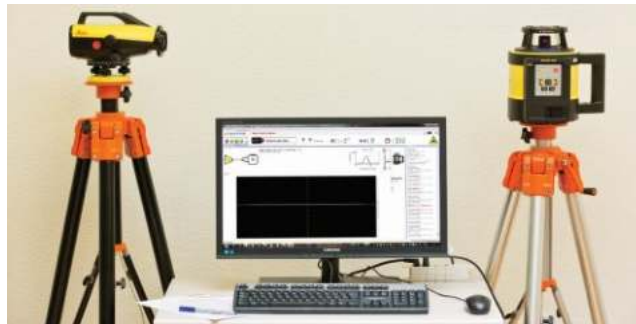

**Figure 9.** Leica CalMaster laboratory calibration system

System allows check accuracy of red and infrared rotating lasers and their stationary beams, in real time, live and precise digital accuracy indication on the screen making manual adjustment of the laser beam. Procedure could be fully automated using the CalMaster software, which contributes to the minimalization of operator influence to the measuring results. One more advance is automatic generation of calibration reports according to ISO 17123-6 standard for evaluating the repeated accuracy of rotating lasers. The Leica CalMaster offers a modern and portable calibration set-up that is unique in the industry, complying with the highest accuracy and repeatability standard ISO 17123-6 for rotating lasers, taking into account the highest productivity, calibration and certification through a fully automatic process. The main component is very accurate level, Leica Sprinter, where the height of the level defines the height of the whole system.

It is important to know, when determining the height of the CalMaster, the height of the different rotation lasers must be taken into consideration. Once the CalMaster is setup at a height, it shouldn't be adjusted. The only time it is allowed to move the CalMaster is when setting or checking the focus. The height of the laser can be adjusted as needed. The minimum distance between CalMaster and the currently used rotation laser must be at least min 0.8m - max 1m. The laser emitted from the rotation laser has to be aligned with the CalMaster horizontally. This horizontal alignment insures that the laser beam goes through the middle of the CalMaster. The Figure10 shows the mentioned alignment. The rotating laser beam has to be centered on the front of the CalMaster. The upper housing of the CalMaster can be used as a reference to find the middle of the instrument. In addition a Laser Receiver can be aligned with the CalMaster this then can be used to align rotation lasers with the CalMaster. The gun sights of the CalMaster and the rotation laser also have to be aligned. This also is a rough alignment, the fine adjustment will be done inside the CalMaster software.



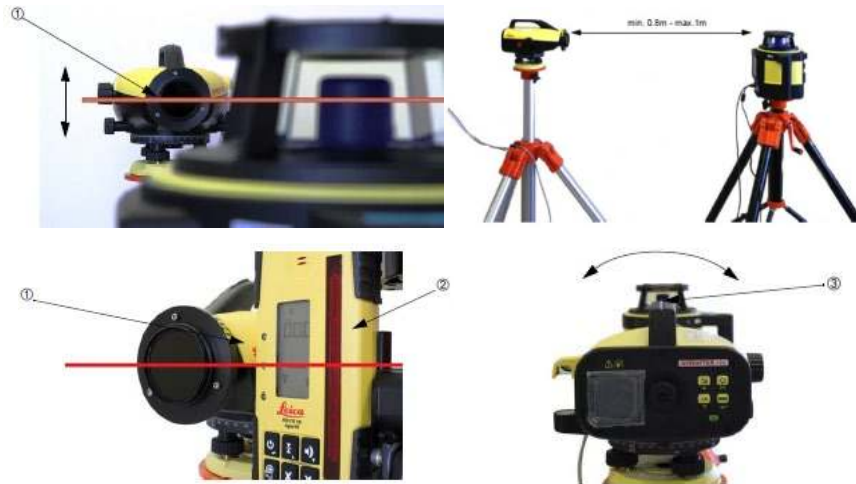

Figure 10. Horizontal alignment between rotating laser and CalMaster

### 3.3. Post processing

With 12 observations and four unknown parameters,  $h, a, b_1, b_2$ , there is an over-determined system, which leads to a parametric adjustment. As the observation formulae are already linear, Table 2 can easily be transferred in matrix notation:

$$r = A\tilde{y} - x, \quad (2)$$

were:

$r$  is residual vector (12x1),

$x = x_B - x_A$  is the (12 × 1) quasi-observation vector of the height differences, with

$x_A$  (12x1) reading vector  $x_{Aj}$ ,  $j = 1, \dots, 12$  of the levelling staff A and

$x_B$  (12x1) reading vector  $x_{Bj}$ ,  $j = 1, \dots, 12$  of the levelling staff B;

$\tilde{y}$  (4x1) is the vector of the unknown parameters

With the design matrix A:

$$A^T = \begin{bmatrix} 1 & 1 & 1 & 1 & 1 & 1 & 1 & 1 & 1 & 1 & 1 & 1 \\ 0 & 0 & 0 & 0 & 1 & 1 & 1 & 1 & -1 & -1 & -1 & -1 \\ -1 & 0 & 1 & 0 & -1 & 0 & 1 & 0 & -1 & 0 & 1 & 0 \\ 0 & 1 & 0 & -1 & 0 & 1 & 0 & -1 & 0 & 1 & 0 & -1 \end{bmatrix} \quad (3)$$

the solution vector of the unknown parameters is:

$$\tilde{y} = \begin{pmatrix} h \\ a \\ b_1 \\ b_2 \end{pmatrix} = (A^T P A)^T P x = N^{-1} A^T P x, \quad (4)$$

The weight matrix p:

$$p = \begin{pmatrix} p_1 & \dots & 0 \\ \vdots & \ddots & \vdots \\ 0 & \dots & p_{12} \end{pmatrix}, \quad (5)$$

is given by  $\text{diag}(p_j) = (1.7, 1.7, 1.7, 1.7, 0.6, 0.6, 0.6, 0.6, 0.6, 0.6, 0.6, 0.6)$

the experimental standard deviation for a sighting distance of 40 m is given by:

$$s = \sqrt{\frac{r^T P r}{v}}, \quad (6)$$

with  $v, v = 12 - 4 = 8$ ,

From all series  $i = 1, \dots, 4$  of observations we can derive the mean values of the parameters

$$\tilde{y} = \frac{1}{4} \sum_{i=1}^4 \tilde{y}_i = \frac{1}{4} \sum_{i=1}^4 \begin{pmatrix} h \\ a \\ b_1 \\ b_2 \end{pmatrix} \quad (7)$$

Finally we get the total deviation of the rotating axis from the true vertical of the rotating laser, referenced to a sighting distance of 40 m:

$$b = \sqrt{b_1^2 + b_2^2}, \quad (8)$$

the overall experimental standard deviation of all series  $i = 1, \dots, 4$  yields:

$$s = \sqrt{\frac{\sum_{i=1}^4 s_i^2}{4}} = \sqrt{\frac{\sum_{i=1}^4 \frac{r_i^T P r_i}{v}}{4}} \quad (9)$$

Herewith we can state the standard uncertainty (Type A) of a height difference,  $h$ , between the instrument level and a levelling staff (reading at the levelling staff) referenced to a sighting distance of 40 m:

$$s_{\text{ISO\_ROLAS}} = s \quad (10)$$

The experimental standard deviation for the parameters of all series can be calculated by

$$s(\tilde{y}) = s \sqrt{\frac{1}{4} \text{dijag}(Q)}, \text{ where } Q = \begin{bmatrix} \frac{1}{12} & 0 & 0 & 0 \\ 0 & \frac{1}{4} & 0 & 0 \\ 0 & 0 & \frac{1}{6} & 0 \\ 0 & 0 & 0 & \frac{1}{6} \end{bmatrix} \quad (11)$$

Thus the standard deviations and the standard uncertainties (Type A), respectively, of the parameters are given by:

$$s_h = u(h) = 0.14s \quad (12)$$

$$s_a = u(a) = 0.25s \quad (13)$$

$$s_{b1} = s_{b2} = s_{b12} = 0.20s \quad (14)$$

Applying the law of variance covariance propagation, the experimental standard deviation of the parameter  $b$  can be written as:

$$s_b = \frac{1}{b} \sqrt{b_1^2 s_{b1}^2 + b_2^2 s_{b2}^2} = \frac{1}{b} \sqrt{(b_1^2 + b_2^2) s_{b12}^2} = s_{b12}, \quad (15)$$

$$s_b = u(b) = 0.20s. \quad (16)$$

#### 4. MEASURING RESULTS

In aim to perform all steps, verification, calibration and conformity assessment of the rotating laser level, it was performed one test procedure using laboratory reference system CalMaster, as well as two field test procedures by two different operators, described as full test method in ISO 17123-6. The results are presented in tables (Table 4, Table 5, Table 6, Table 7, Table 8, Table 9 and Table 10):

**Table 4.** Verification and calibration rotating laser level using the CalMaster system

Sample specification	Self-leveling accuracy, maximum deviation from horizon: $\pm 10''$ , 1,6 mm per 30 m.
Test results for grade from horizon:	Maximum deviation from horizon $\pm 6''$ , 1 mm per 30 m
Standard deviation:	$\pm 3''$ , 0,5 mm per 30 m
Test procedure	The measurement are determined with a test tool specifically to develop and designed for testing rotation lasers under laboratory conditions. Test Equipment: Leica CalMaster for rotation lasers, Cal Master Focus Check,
Temperature	20 degrees C
Pressure	1018 hPa
Humidity	35%

Measured values	X1 arcsec	X2 arcsec	Y1 arcsec	Y2 arcsec
Set 1 1/1	-4,3	-5,8	-6,7	-5,3
Set 2 1/1	-5,4	-6,7	-6,1	-6,3
Set 3 1/1	-6,0	-5,9	-5,8	-5,7
Result plane X <sub>1</sub>	Calibration value 0,5''		standard deviation +/- 0.7	
Result plane X <sub>2</sub>	Calibration value - 0,2''		standard deviation +/- 0.5	
Cone:	-5,8''			
Traceability	The test equipment used is traceable to national standards or recognized procedure.			
Compliance:	The test results are within the specification of the product			

Verification and calibration rotating laser level using ISO 17123-6 full method ISO 17123-6 is given below.

*Table 5. Measuring data from the first operator*

		SET 1			SET 2			SET 3			SET 4		
Position	j	X <sub>Aj</sub>	X <sub>Bj</sub>	X <sub>j</sub>	X <sub>Aj</sub>	X <sub>Bj</sub>	X <sub>j</sub>	X <sub>Aj</sub>	X <sub>Bj</sub>	X <sub>j</sub>	X <sub>Aj</sub>	X <sub>Bj</sub>	X <sub>j</sub>
		m	m	m	m	m	m	m	m	m	m	m	m
1	1	1.241	1.516	0.275	1.766	2.043	0.277	1.915	2.193	0.278	2.279	2.555	0.276
	2	1.241	1.518	0.277	1.766	2.043	0.277	1.915	2.192	0.277	2.278	2.555	0.277
	3	1.239	1.517	0.278	1.765	2.043	0.278	1.915	2.192	0.277	2.280	2.556	0.276
	4	1.239	1.512	0.273	1.765	2.043	0.278	1.915	2.192	0.277	2.280	2.556	0.276
2	5	1.886	2.161	0.275	2.415	2.693	0.278	2.756	3.033	0.277	2.898	3.178	0.280
	6	1.885	2.161	0.276	2.415	2.693	0.278	2.756	3.033	0.277	2.899	3.178	0.279
	7	1.885	2.160	0.275	2.415	2.692	0.277	2.756	3.033	0.277	2.898	3.178	0.280
	8	1.885	2.160	0.275	2.414	2.691	0.277	2.756	3.034	0.278	2.899	3.177	0.278
3	9	2.194	2.468	0.274	2.455	2.733	0.278	2.886	3.163	0.277	3.228	3.505	0.277
	10	2.194	2.467	0.273	2.455	2.733	0.278	2.886	3.162	0.276	3.229	3.505	0.276
	11	2.194	2.469	0.275	2.455	2.733	0.278	2.886	3.163	0.277	3.230	3.505	0.275
	12	2.194	2.467	0.273	2.456	2.733	0.277	2.886	3.163	0.277	3.229	3.505	0.276
Σ		21.277	24.576	3.299	26.542	29.873	3.331	30.228	33.553	3.325	33.627	36.953	3.326

*Table 6. Measuring data from the second operator*

		SET 1			SET 2			SET 3			SET 4		
Position	j	X <sub>Aj</sub>	X <sub>Bj</sub>	X <sub>j</sub>	X <sub>Aj</sub>	X <sub>Bj</sub>	X <sub>j</sub>	X <sub>Aj</sub>	X <sub>Bj</sub>	X <sub>j</sub>	X <sub>Aj</sub>	X <sub>Bj</sub>	X <sub>j</sub>
		m	m	m	m	m	m	m	m	m	m	m	m
1	1	1.759	2.035	0.276	1.767	2.043	0.276	1.916	2.193	0.277	2.279	2.554	0.276
	2	1.758	2.034	0.276	1.767	2.043	0.276	1.916	2.192	0.276	2.278	2.554	0.277
	3	1.758	2.034	0.276	1.766	2.043	0.277	1.916	2.192	0.276	2.280	2.555	0.276
	4	1.758	2.034	0.276	1.766	2.043	0.277	1.916	2.192	0.276	2.280	2.555	0.276
2	5	2.599	2.875	0.276	2.416	2.693	0.277	2.758	3.033	0.275	2.897	3.177	0.280
	6	2.599	2.875	0.276	2.416	2.693	0.277	2.758	3.033	0.275	2.898	3.177	0.279
	7	2.599	2.875	0.276	2.416	2.692	0.276	2.758	3.033	0.275	2.897	3.177	0.280
	8	2.599	2.876	0.277	2.415	2.691	0.276	2.758	3.034	0.276	2.898	3.176	0.278
3	9	2.728	3.005	0.277	2.456	2.733	0.277	2.888	3.163	0.275	3.227	3.504	0.277
	10	2.728	3.004	0.276	2.456	2.733	0.277	2.888	3.162	0.274	3.228	3.504	0.276
	11	2.729	3.005	0.276	2.456	2.733	0.277	2.888	3.163	0.275	3.229	3.504	0.275
	12	2.729	3.005	0.276	2.457	2.733	0.276	2.888	3.163	0.275	3.228	3.504	0.276
Σ		28.343	31.660	3.317	26.553	29.873	3.320	30.246	33.553	3.307	33.620	36.946	3.325

Table 7. First operator – results of measuring

	set1	set2	set3	set4	S <sub>ISO ROLAS</sub> =	0,71	mm
h=	0,276362	0,276725	0,275728	0,276836	U <sub>ISO ROLAS</sub> =	1,43	mm
a=	-6,5E-06	-0,00012	0,000289	0,001625	h=	0,28	m
b <sub>1</sub>	-0,00012	0,00015	-0,00027	-0,00023	a=	0,000448	m
b <sub>2</sub>	-0,00012	-3,3E-05	-0,00023	0,000383	b <sub>1</sub> =	-0,00012	m
s	0,394	0,585875	0,650189	1,058286	b <sub>2</sub> =	-5,2E-08	m
					b=	0,000117	m

Table 8. Second operator – result of measuring

	set1	set2	set3	set4	S <sub>ISO ROLAS</sub> =	0,67	mm
h=	0,276117	0,277558	0,277133	0,276892	U <sub>ISO ROLAS</sub> =	1,34	mm
a=	2,36E-16	-0,00013	0,00025	0,001625	h=	0,28	m
b <sub>1</sub>	-0,00012	0,00015	-0,00027	-0,00023	a=	0,000437	m
b <sub>2</sub>	-0,00012	-3,3E-05	-0,00023	0,000383	b <sub>1</sub> =	-0,00012	m
s	0,366288	0,584166	0,458712	1,058497	b <sub>2</sub> =	5,9E-17	m
					b=	0,000117	m

Table 9. Conformity assessment tests

No	Null hypothesis	Test statistic	Question
1	$s = \sigma$	$s \leq \sigma \cdot \sqrt{\frac{X_{1-\alpha}^2(v)}{v}}$	The null hypothesis stating that the experimental standard deviation, s, is smaller than or equal to a theoretical or a predetermined value, $\sigma$ ,
2	$\sigma = \tilde{\sigma}$	$\frac{1}{F_{1-\alpha/2}(v,v)} \leq \frac{s_1^2}{s_2^2} \leq F_{1-\alpha/2}(v,v)$	In the case of two different samples, a test indicates whether the experimental standard deviations, s and $\tilde{s}$ , belong to the same population.

Table 10. Conformity assessment results

s <sub>1</sub> =	1,43	Measurement uncertainty			
s <sub>2</sub> =	1,34				
v <sub>1</sub> =	8				
v <sub>2</sub> =	8				
F <sub>1-alfa/2,v,v</sub> =	4,43				
s <sub>1</sub> <sup>2</sup> /s <sub>2</sub> <sup>2</sup> =	1,14				
Test statistic	0,23				
s <sub>1</sub> =	0,276	High difference			
s <sub>2</sub> =	0,277				
v <sub>1</sub> =	8				
v <sub>2</sub> =	8				
F <sub>1-alfa/2,v,v</sub> =	4,43				
s <sub>1</sub> <sup>2</sup> /s <sub>2</sub> <sup>2</sup> =	0,996				

Test statistic	0,23	≤	0,996	≤	4,43
$\sigma=$	1,6	Measurement uncertainty			
S <sub>ISO_LEV</sub>	1,42				
v	8				
$\chi^2_{1-\alpha, v}$	15,51				
Test statistic	2,228				
	1,42	≤	2,23	TRUE	
$\sigma=$	1,6	Measurement uncertainty			
S <sub>ISO_LEV</sub>	1,34				
v	8				
$\chi^2_{1-\alpha, v}$	15,51				
Test statistic	2,23				
	1,34	≤	2,23	TRUE	

Traceability: The results of the calibration are traceable to the national standard of the Frequently Stabilized Helium-Neon Laser (DMDM, Serbia).

## 5. CONCLUSION

Quality is an important factor when it comes to any product or service. With the high market competition, quality has become the market differentiator for almost all products and services. There are many methods followed by organizations to achieve and maintain required level of quality for different types of products, equipment and services.

The most important characteristics of measuring instruments and measuring equipment are changing over the time. These changes are caused by environmental effects, mishandling, wear of measurement surface, etc. It is very important to check, review and follow the long term of equipment quality check, in the aim to assure that the equipment intended to be used meets the requirements of the project.

Building projects first have to give save products, as well as they are very expensive, so securing quality in all phases of project is crucial. Since one phase consist from different process and procedures, and further from recourses and methods, all single part of project management must be quality assured. When it comes from building equipment, rotating lasers are very useful for securing really horizontal and vertical levels during the building process. Very often, project by self insists on special range of accuracy and precision, so criteria with respect to technical specifications is given in advance.

There are different types of rotating lasers, with different technical specification. It is important to secure that the rotating laser has ability to respond to project requirements, so there are officially recognized norms recommended for verification, testing and calibrating it.

In this paper has shown interpretation of international norm ISO 17123-6 from two different approaches. First one is laboratory reference systems as automatized systems for rotating lasers verification, and second one is field method for uncertainty measurement assessment type A.

Laboratory reference system show that the rotating laser has standard deviation confirmed within declared values by manufacturer. Field method is performed by two operators, with many repeated measurements, giving the assessment of results for high difference, deviation of laser beam in horizontal and vertical sense, as well as experimental standard deviation of high difference.

Using the recommended statistic test it is shown that results of measurement obtained by two different operators belong to the same population, as well as results are confirmed within range values given by manufacturer.

It is important to say, the ISO 17123-6 qualified calibration certificate is necessary to large contractors bidding for governmental projects, as well as small to medium size contractors bidding for projects from regional authorities, including rental companies upgrading their services and expanding client basket and potentially any laser owner needing written confirmation for his quality process.

**LITERATURE**

- [1] James P.Dux, Handbook of Quality Assurance for the Analytical Chemistry Laboratory, Springer Science & Business Media, 06.12.2012. - 204 page.
- [2] BIPM, IEC, IFCC, ILAC, ISO, IUPAC, IUPAP and OIML. „International Vocabulary of Metrology – Basic and General Concepts and Associated Terms (VIM 3rd edition) JCGM 200:2012“, 2012.
- [3] Universitas Tartuensis. „The concept of measurement uncertainty“, Internet: <https://sisu.ut.ee/measurement/introduction-concept-measurement-uncertainty>
- [4] Tom Lish. „What is Measurement Traceability“, Internet: <https://www.setra.com/blog/what-is-measurement-traceability>, September 05, 2016.
- [5] 2010 Johnson Level & Tool Mfg. Co., Inc. „Spirit Level, Laser Levels & Construction Measuring Tool Leader“, internet <http://www.johnsonlevel.com/News/RotaryLaserLevels>
- [6] International Organization for Standardization, „ISO 10012:2003 Measurement management systems — Requirements for measurement processes and measuring equipment“, Genève 2003.
- [7] International Organization for Standardization, „ISO 17123-6:2012 Optics and optical instruments — Field procedures for testing geodetic and surveying instruments — Part 6: Rotating lasers“, Genève 2012.
- [8] Zrinjski, Mladen & Barković, Đuro & Gudelj, Marina, „Testing and Analysis of the Measurement Quality of the Rotating Laser System“ Geodetski List. Vol. 73 (96). pp 109-128. year 2019.
- [9] Leica Geosystems AG, “Leica CalMaster 100 - Grow and bond your distribution through unique service offering”, Heerbrugg 2014.
- [10] Google images, “Accuracy and precision” <https://i.pinimg.com/originals/ea/2e/ae/ea2eae9ca6992d2ff76deffa8f470d28.jpg>